

Workstation on Wheels

# OP-CN01-HG

Non-Powered Medical Cart



## Features

- Compact Lightweight Design
- Anti-Microbial Surface Coating
- Rear Handle
- Accessory Expansion Compatible
- Swivel Display Mount

## Specifications

### Complete System

Overall Load Capacity	33lbs. (15kg)
Net Weight	68.3lbs. (31kg)
Packaged Dimensions	31.5"W x 25.2"D x 57.9" H (800 x 640 x 1450mm)
Accessory Compatible	Yes

### Display System

Hinge Module Swivel	N/A
Hinge Tilt	-5°(down) ~ +25°(up)
Hing Pivot	360°
User Torque Adjust	Available
Display Mounting Pattern	100 x 100mm 75 x 75mm
Display Support Type	Single Monitor
Panel Size Support	≤24" Monitor
Max Weight Load	17.6lbs (8kg)
Height Adjust Range	5.12" (130mm)
Height Tension Torque	Yes
Cable Management	Yes

### Working Space

Desk	Open Workspace
Dimensions	20.35" x 10.28" (571 x 261mm)
Max Load	16.5lbs (7.5kg)
Skidproof at Edge	Yes
Rear Handle	Yes
Surface Coating	Yes

### Storage & Inputs

Compartment Dimensions	16.73" W x 12.8" D x 3.54" H (425 x 325 x 90mm)
Key Lock	Yes
Keyboard Tray Dimensions	17.68" x 8.15" (449 x 207mm)
Keyboard Height	1.63" (41.5mm)
Tilt	Max 12°(backward)
Display Support Type	Single Monitor
Panel Size Support	≤24" Monitor
Max Weight Load	17.6lbs (8kg)
Height Adjust Range	5.12" (130mm)
Height Tension Torque	Yes
Cable Management	Yes

### Base System

Caster	4 Wheels, Low Noise
Caster Locking Brake	Yes, On Two Front Wheels
Main Lift Handle	Yes
Height Adjust Range	19.7" (500mm)
Main Lift Tension Adjust	Yes, Make Sure to Lock Display & Main Lift Before Moving
RoHS Compliant	Yes

## Mobile Medical Cart

### Dimension / Unit: mm

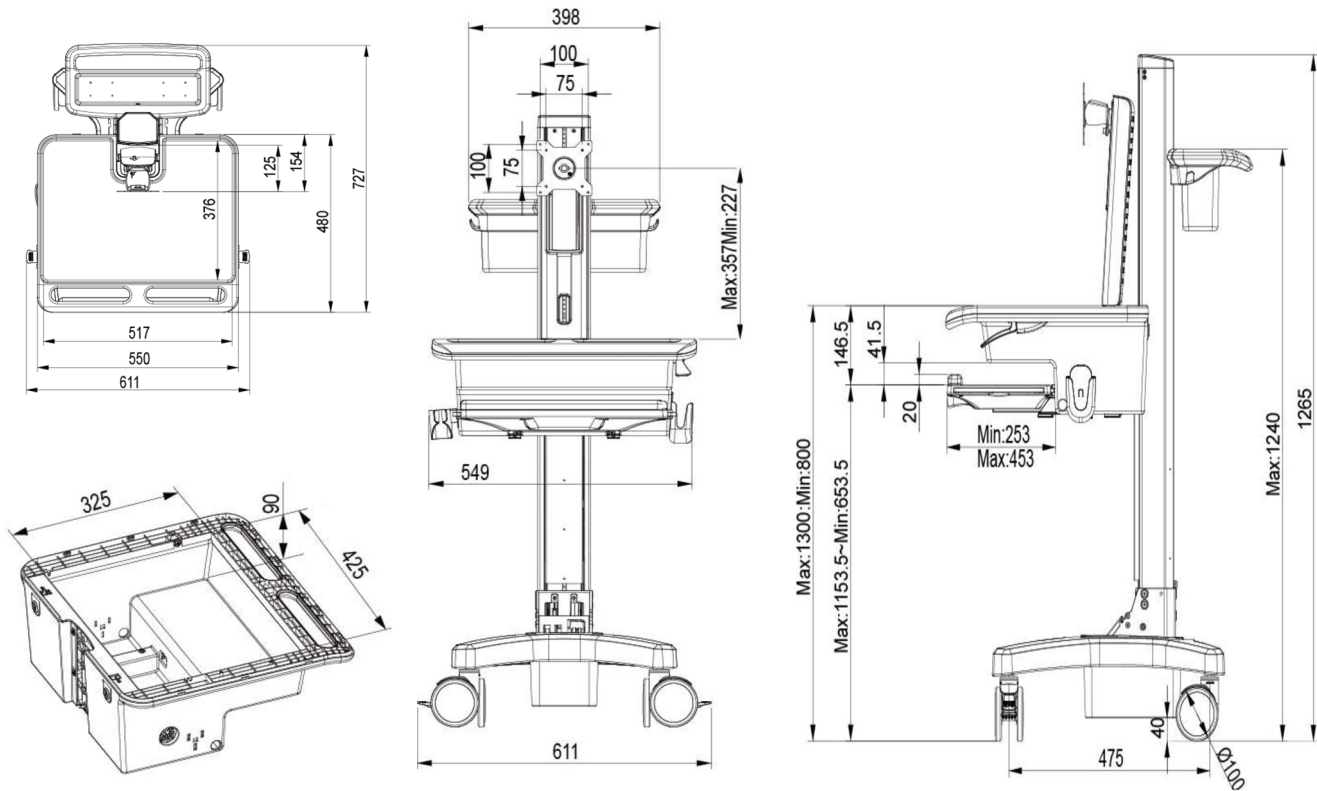

### Ordering Information

- » OP-CNH01-HG  
Non-Powered Medical Cart

### Optional Accessories

- » OP-ACB100-HG  
Mobile Nursing Station Lock Box
- » OP-ACB140-HG  
Mobile Nursing Station 4 Drawer Lock Box
- » OP-ACG200-HG  
Mobile Nursing Waste Bins